

Technical Data

QES200NG G

Spark Ignition Gas Engine
Generating set

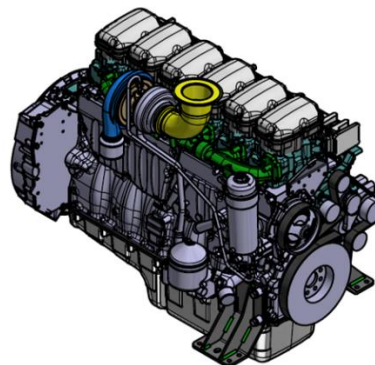

Basic technical data

Engine Manufacture	Quantum
Engine Model	Q5.9TASI
Number of cylinders	5
Cycle	Four stroke
Induction system	Turbocharged and charge cooled
Compression ratio	12.5:1
Bore	130 mm
Stroke	160 mm
Cubic capacity	9.3 liters
Direction of rotation (view from front)	Clockwise
Firing order	1,2,4,5,3
Alternator Manufacture	Mecc Alte
Phase	3 Phase
Voltage	400-415V
Assumed Power factor	1

Dimensions and Connections

Hot water Flow	NA
Hot Water Return	NA
Intercooler connections	NA
Gas Connection (natural gas (Biogas))	DN50 Flange DN50 Lange
Exhaust Connection	6"
Drain and condensation connections	1" BSP
Condensation should have a trap included to prevent exhaust gases escaping, done by customer	

Overall dimensions (close fit canopy)

Height	2600 mm
Length	5200 mm
Width	2000 mm
Weight	4,100kg(approx.)

If the engine is to operate in ambient conditions other than those of the test conditions, suitable adjustments must be made for the changes. For full details, contact QES or KVT

General installation		Units
Fuel Type	Natural gas	
Mechanical output	174	kW
Electrical output Max (Stand-by)	160	kWe
	200	kVA
Natural gas flow	1695	Mj/h
Exhaust gas outlet temperature	535	°C
Jacket water exit temperature (max)	90	°C
Charge cooler entry temperature (max)	35	°C
Electrical efficiency	38.5	%
Voltage	400-415	V
Power factor	1	pf
Actual alternator efficiency	93	% @ pf 1
Emissions	CO mg/Nm ³	NA
	NOX mg/Nm ³	NA

Caution: The airflows shown in this table will provide acceptable cooling for an open power unit operating in ambient temperatures of up to 53 °C (127 °F) or 46 °C (114.8 °F) if a canopy is fitted. If the power unit is to be enclosed totally, a cooling test should be done to check that the engine cooling is acceptable. If there is insufficient cooling, contact us.

Construction

- Rigid base frame made of profiled steel including engine bund.
- Direct coupled engine and generator assembly with flexible drive plate.
- Engine generator assembly flexibly mounted on the base frame.
- Heat dump/radiator mounted on generator frame. On the larger sets radiator may be disconnected and shipped loose to fit inside ISO shipping container for export.

Exhaust System

Primary exhaust silencer is mild steel and is rated at industrial sound level (85DBA @1 meter).

Gas train

Includes; Manual shut off valve, Filter, Double block solenoid, 30-50mbar pressure regulator.

High pressure train available on request.

Canopy

- Highly effective sound enclosure of sheet steel construction, powder coated, Handles and locks on each side. Insulation thickness 32mm, Constructed from 2 mm steel plate. Air passages acoustically lined and waterproof.

Heat recovery system (Optional)

- Comprising a variable speed water pump, pressure expansion vessel, pressure relief valve and drain valves.
- Heat recovery from the engine and exhaust heat exchanger to a stainless steel plate heat exchanger.
- Temperature control achieved by varying the water pump speed and a 3 port divert valve to an external heat dump circuit.
- The secondary circuit monitors flow and return temperatures and operates a 3 port mixing valve to maintain flow temperature to a setpoint. Excess heat not recovered is diverted to the heat dump radiator in the primary circuit.

Control Panel

Sheet metal enclosure (1200x600x400mm). ComAp PLC based system enables auto and manual control for start/stop, voltage control, mains synchronization, load control. Remote control Data access through Ethernet (customer connection required). Control and load cables not supplied, and connection will be required between panel and engine sub panel once installed.

Engine control

Start/stop, engine speed control, monitoring for engine coolant inlet and outlet temperatures and exhaust temperature. Circulating pump operating status and variable speed control to maintain cylinder head temperature.

Alternator control

Control of the alternator mounted AVR for voltage output, power output and Power Factor.

Emergency stop

Canopy mounted push button with external link.
If external EST operated engine will stop./
If Canopy ESB operated only the engine will stop

Critical points

- T1 Engine coolant outlet temperature
- T2 Engine coolant inlet temperature
- T3 Exhaust temperature
- T4 Secondary water feed temperature
- V1 Primary circuit divert valve position 0 -100%
- V2 Secondary circuit mixing valve position 0-100%

Emissions reduction (Optional)

Standard 3 way catalyst can be add at time of order to reduce the NOX and CO2 for site requirement or regulation (naturally aspirated) For turbocharged or lean-burn engines SCR low NOX systems can be added.

